

# RAD-Jupiter

## Rugged 7-Port Managed Switch for Automotive Ethernet (100/1000BASE-T1)

If you are working in Automotive Ethernet development, a switch is a valuable tool for your bench. If the application is simple, forwarding 100BASE-T1 messages from port to port based on MAC address, Intrepid's RAD-Pluto will meet your needs and give you an interface to the CAN and LIN busses. But, if the application involves AVB/TSN, a managed switch is required to support the associated protocols.

Intrepid's RAD-Jupiter is a rugged 7-port managed switch designed specifically for bench and vehicle network development. In addition to its Ethernet functionality, it integrates many of the key CAN, LIN, and scripting features found in our ValueCAN 4 family of tools.

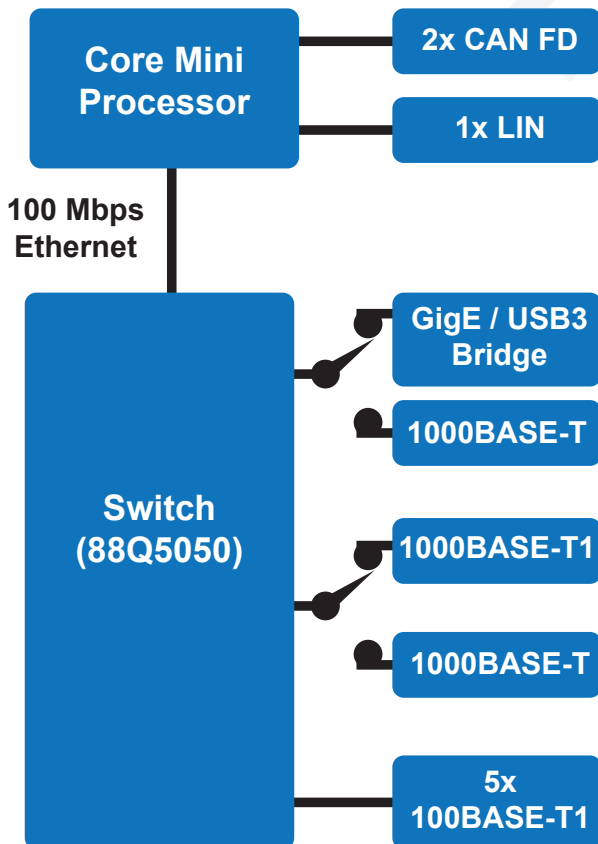

### Features

- 7-port switch with selectable Gigabit PHY's
- Embedded AVB/TSN protocol stack
- Embedded processor for scripting and embedded C applications
- Intrepid Security Module supporting cybersecurity applications
- 8x dual purpose LEDs for network status and device configuration
- Rugged aluminum case with shock-absorbing boots
- Flexible power options (DB9/USB-C/barrel-jack)
- Field-upgradeable flash firmware

### Network Specifications

- 7 port switch:
  - 5x 100BASE-T1 ports
  - 1x 1000BASE-T or 1000BASE-T1 port
  - 1x 1000BASE-T or USB/GigE bridge
- 2x CAN FD channels with programmable termination
- 1x LIN channel



**INTREPID**  
CONTROL SYSTEMS  
www.intrepidcs.com

1850 Research Drive  
Troy, MI 48083 USA  
Phone: +1 (586) 731-7950  
Fax: +1 (586) 731-2274



www.aeta-rice.com

# RAD-Jupiter

## Switch Protocols and Features

- AVB/TSN
  - 802.1Qav – Forwarding and Queuing for Time-Sensitive Streams (FQTSS)
  - 802.1AS – Generalized Precision Timing Protocol (gPTP)
  - 802.1Qbv - Enhancements for Scheduled Traffic  
(*Time Aware Shaping in future firmware release*)
  - Static Stream Reservation
- IEEE 802.1Q tag support with 4096 VLANs
- Port mirroring
- Ingress policing and rate limiting
- Ternary Content Addressable Memory (TCAM)

## AVB/TSN Use Cases

- AVB compliant bridge supporting static streams
- AVB/TSN network sensitivity analysis (Insert latency or switch hops; Add additional ECU's for more BE or stream traffic.)

## Media Converter

The BASEs are covered! 100BASE-T1, 1000BASE-T1, 1000BASE-T, and a USB/GigE Bridge. A media converter is as simple as setting up bidirectional port forwarding between any 2 ports. The RAD-Jupiter can be configured for 2x 100BASE-T1 converters or 1x 1000BASE-T1 converter without losing the use of the remaining ports of the switch!

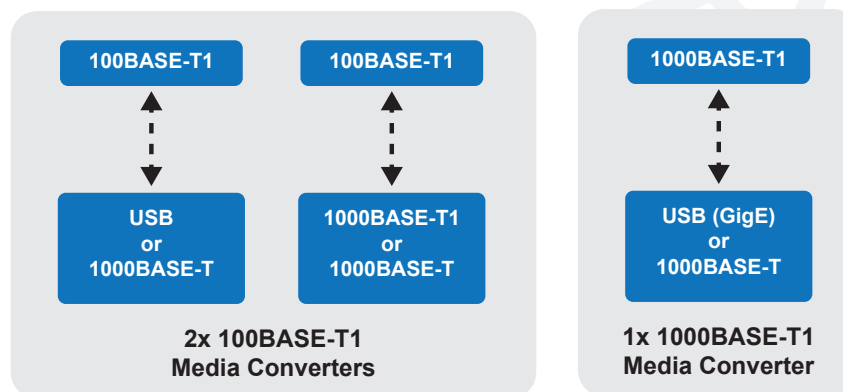

# RAD-Jupiter

## Gateway Applications

In addition to providing a network interface to your PC, the embedded processor in the RAD-Jupiter can be programmed to run real-time applications such as network gateways. Applications can be programmed in Vehicle Spy's Function Blocks or in C Code which is easily compiled to run on the embedded processor.

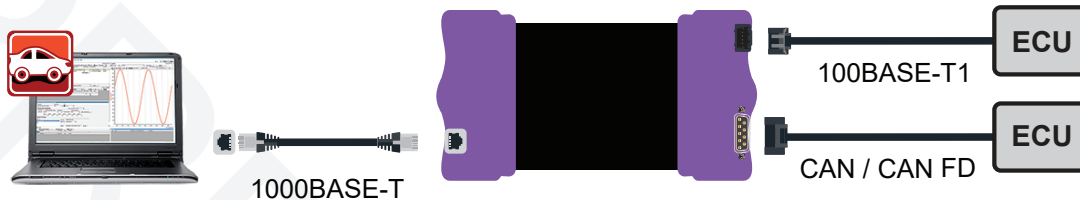

Using the RAD-Jupiter as a Gateway between CAN/CAN FD and Ethernet

## TCAM Applications

Ternary Content Addressable Memory, or TCAM, is specialized hardware within the switch which can examine data in specific areas of the Ethernet frame and take actions based on bit patterns at wire speed!

- Override VLAN, Frame Priority, and Queue Priority
- Whitelisting/Blacklisting
- Message Filter Based Port Forwarding
- User Defined Network Diagnostic Counters
- Arbitrary Firewalls based on any bit pattern within the first 96 bytes of the frame

## Vehicle Spy Ethernet Applications

While RAD-Jupiter does not function as an Automotive Ethernet Active Tap, this does not prevent it from taking advantage of some of Vehicle Spy's many Ethernet applications.

- AVDECC Controller
- SOME I/P Discovery, Subscription, and RPC
- DoIP
- GUI driven Gateway Builder

## Device Specifications

- Power supply: 4.5V - 40V operation
- Temperature range: -40°C to 85°C
- One-year limited warranty
- Fully-isolated USB with Microsoft-certified USB drivers
- Dimensions: 3.98 × 11.22 × 18.65 cm (1.56" × 4.42" × 7.34")
- Weight: 595 g (1.31 lb)

## Ordering Information

Part Number	Description
RAD-JUPITER	RAD-JUPITER Device

Specifications subject to change; please contact Intrepid for the latest information. All trademarks are the property of their respective owners.

Rev. 20200616



**INTREPID**  
CONTROL SYSTEMS  
www.intrepidcs.com

1850 Research Drive  
Troy, MI 48083 USA  
Phone: +1 (586) 731-7950  
Fax: +1 (586) 731-2274



www.aeta-rice.com